

Forest 3000 Lion XLF

Nuovo murale refrigerato con frontale fisso ultra-basso per salumi, latticini, frutta, verdura e carni che, grazie al frontale di soli 170 mm rappresenta un ulteriore trionfo del visual merchandising Costan. Disponibile in varie configurazioni, LION XLF dispone di un eccellente rapporto tra superficie occupata e profondità utile. Due diversi mobili di testa e svariati allestimenti interni completano un'offerta ricca ed estremamente flessibile. Accurate soluzioni tecnologiche assicurano la corretta conservazione del prodotto esposto.

New refrigerated wall-cabinet with fixed extra-low front for sausages, dairy products, fruits, vegetables and meat. With a front as low as 170 mm, this multideck represents a further victory of Costan's visual merchandising. Available in various configurations, the LION XLF features an excellent occupied surface/useful depth ratio. Two different head cabinets and several types of internal equipment possibilities complete a rich and extremely flexible range. Accurate technological solutions-guarantee impeccable preservation of the foods displayed.

Nouveau meuble mural réfrigéré avec façade fixe ultra-basse pour charcuterie, produits laitiers, fruits, légumes et viandes qui, grâce à la façade de seulement 170 mm représente un autre triomphe des techniques marchandes visuelles Costan. Disponible en différentes configurations, LION XLF dispose d'un excellent rapport entre surface occupée et profondeur utile. Deux têtes de gondoles différentes et plusieurs aménagements internes complètent une offre riche et extrêmement flexible. Des solutions technologiques soignées assurent une conservation correcte du produit exposé.

Das neue Kühlregal mit ganz niedriger, nur 170 mm hoher, feststehender Vorderverkleidung für die Auslage von Wurstwaren, Milchprodukten, Obst, Gemüse und Fleisch, ist ein weiterer Erfolg des „Visual merchandising“ des Hauses Costan. Das in verschiedenen Ausführungen erhältliche LION XLF-Kühlregal besitzt ein äußerst günstiges Verhältnis zwischen Platzbedarf und Nutzraum. Zwei unterschiedliche Kopfmöbel und verschiedene Innenausrüstungen vervollständigen das reichhaltige, extrem flexible Angebot. Sorgfältige technologische Lösungen garantieren die korrekte Aufbewahrung der im Kühlregal ausgestellten Waren.

Nuevo mueble mural refrigerado con frente fijo ultra-bajo para fiambres, lácteos, fruta, verdura y carnes que, debido a su frente de tan sólo 170 mm, representa otro triunfo del merchandising visual de Costan. Disponible en varias configuraciones, LION XLF cuenta con una excelente relación entre la superficie ocupada y la correspondiente profundidad útil. Dos distintos muebles de cabeza y numerosas posibilidades de equipamiento interno completan una gama rica y extremadamente flexible. Soluciones tecnológicas precisas y acertadas garantizan la correcta conservación de los alimentos expuestos.

Novo móvel de parede refrigerado com frontal fixo super baixo para enchidos, laticínios, frutas, verduras e carnes que, graças ao frontal de só 170 mm, representa um triunfo a mais para o *visual merchandising* Costan. Disponível em várias versões, o LION XLF oferece uma excelente relação entre superfície ocupada e profundidade útil. Dois móveis terminais diferentes e diversas configurações internas completam uma proposta rica e extremamente flexível. Soluções técnicas acuradas asseguram a correcta conservação do produto exposto.



Grande superficie espositiva
Large display surface
Grande surface d'exposition
Große Auslagenfläche
Grande superficie de exposición
Grande superficie de exposição

Frontale 170 mm
Front 170 mm
Frontal 170 mm
Front 170 mm
Frente 170 mm
Parte frontal 170 mm

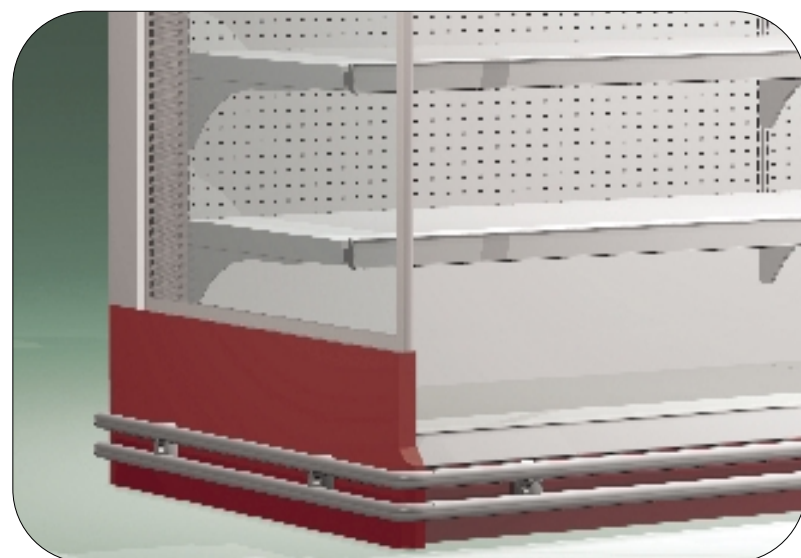

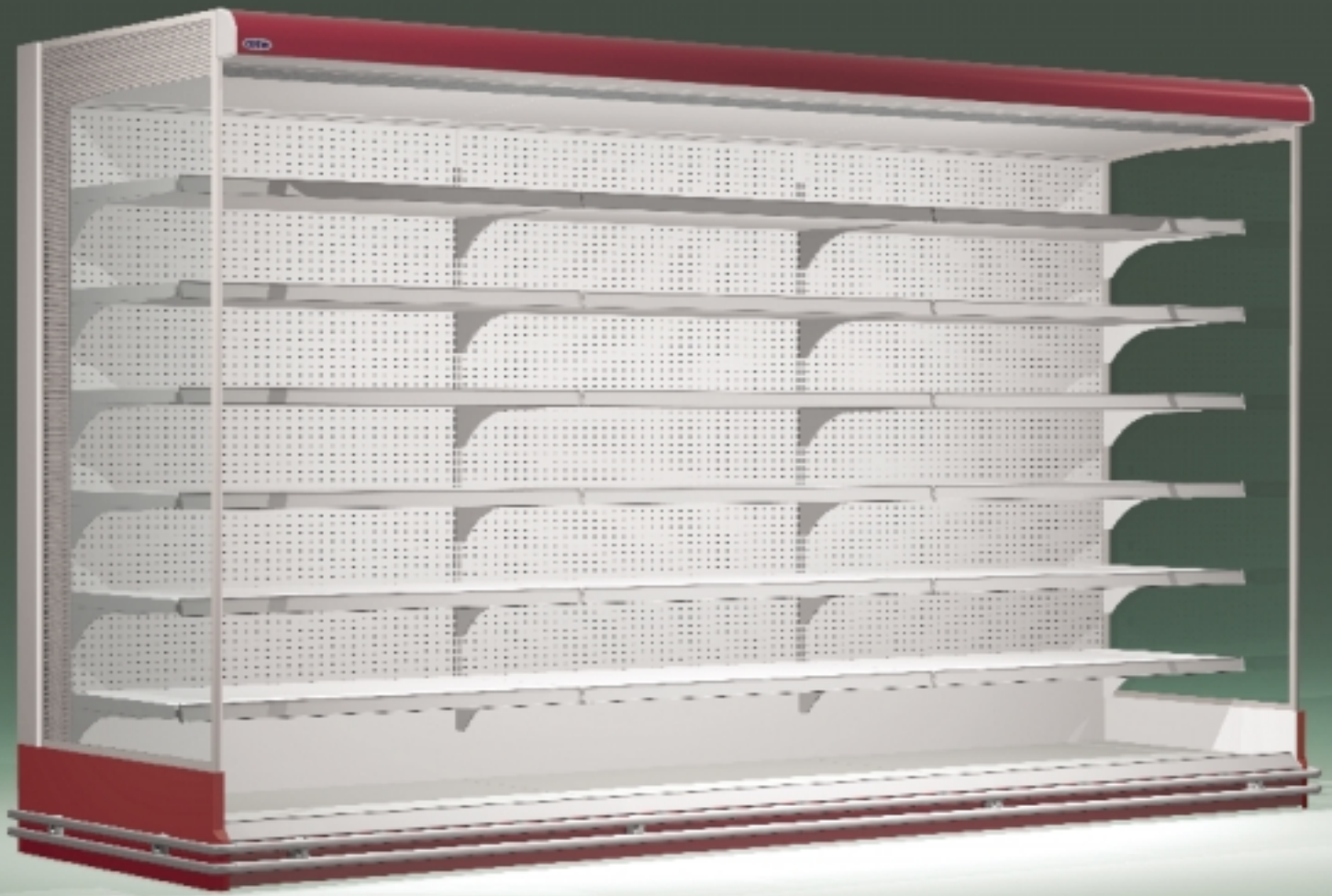

LION XLF 20 L2

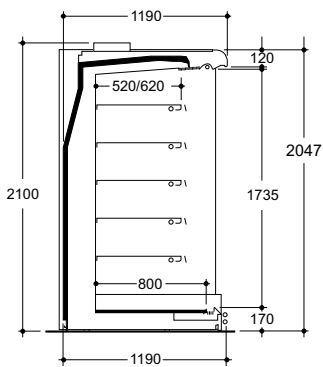

125	●
188	●
250	●
375	●
MT 188	●
MT 250	●

LION XLF 20 L1

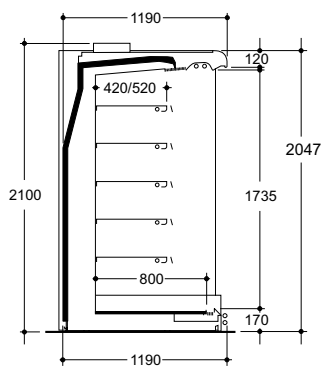

125	●
188	●
250	●
375	●
MT 188	●
MT 250	●

LION XLF 22 L1

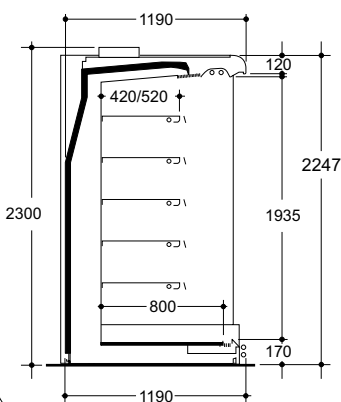

125	●
188	●
250	●
375	●
MT 188	●
MT 250	●

LION XLF 22 L2

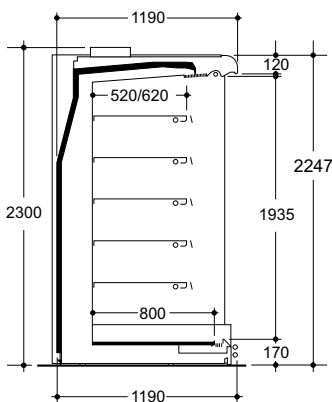

125	●
188	●
250	●
375	●
MT 188	●
MT 250	●

LION XLF 20 N

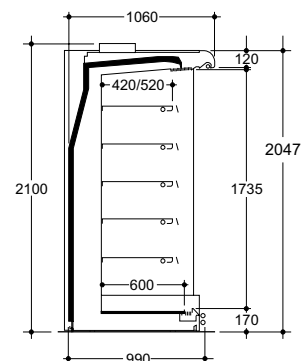

125	●
188	●
250	●
375	●
MT 188	●
MT 250	●